

# STANDARD AND OPTIONAL ACCESSORIES

MODEL	LS-800	LS-800M	LS-800Y	LS-1000	LS-1000M	LS-1100
Hi-low Gearbox Spindle	☆	☆	☆	☆	☆	☆
Hydraulic servo turret	☆	☆	☆	☆	☆	☆
Hydraulic tailstock	☆	☆	☆	☆	☆	☆
Automatic PIN actuated tailstock	☆	☆	☆	☆	☆	☆
Boring bar tool holder (4 Pcs)	☆	☆	☆	☆	☆	☆
U-drill tool holder (1 Pcs)	☆	☆	☆	☆	☆	☆
Angle type tool holder (1 Pcs)	☆	☆	☆	☆	☆	☆
OD tool holder (1 Pcs)	-	☆	☆	-	☆	-
X axis live tool holder (1 Pcs)	-	☆	☆	-	☆	-
Z axis live tool holder (1 Pcs)	-	☆	☆	-	☆	-
Boring bar bush 6ø	◆	◆	◆	-	-	-
Boring bar bush 8ø	◆	◆	◆	-	-	-
Boring bar bush 10ø	◆	◆	◆	-	-	-
Boring bar bush 12ø	☆	☆	☆	-	-	-
Boring bar bush 16ø	◆	◆	◆	-	-	-
Boring bar bush 20ø	◆	◆	◆	☆	☆	☆
Boring bar bush 25ø	◆	◆	◆	☆	☆	☆
Boring bar bush 32ø	☆	☆	☆	☆	☆	☆
Boring bar bush 40ø	☆	☆	☆	☆	☆	☆
Boring bar bush 50ø	-	-	-	☆	☆	☆
U-drill bush 16ø	☆	☆	☆	-	-	-
U-drill bush 20ø	☆	☆	☆	-	-	-
U-drill bush 25ø	☆	☆	☆	-	-	-
U-drill bush 32ø	☆	☆	☆	☆	☆	☆
U-drill bush 40ø	☆	☆	☆	☆	☆	☆
U-drill bush 45ø	-	-	-	☆	☆	☆
U-drill bush 50ø	-	-	-	☆	☆	☆
Drill bush MT-1	◆	◆	◆	-	-	-
Drill bush MT-2	◆	◆	◆	-	-	-
Drill bush MT-3	◆	◆	◆	-	-	-
Drill bush MT-4	☆	☆	☆	☆	☆	☆
Drill bush MT-5	-	-	-	☆	☆	☆
Working lamp	☆	☆	☆	☆	☆	☆
Tool box	☆	☆	☆	☆	☆	☆
Operation manual	☆	☆	☆	☆	☆	☆
Hydraulic chuck	☆	☆	☆	☆	☆	☆
Foot switch	☆	☆	☆	☆	☆	☆
Chip conveyor	◆	◆	◆	◆	◆	◆
Chip cart	◆	◆	◆	◆	◆	◆
Manual steady rest ø50-350	◆	◆	◆	◆	◆	◆
Hydraulic steady rest SLU3.2(ø50-ø200)	◆	◆	◆	◆	◆	◆
Hydraulic steady rest SLU-4(ø30-ø245)	◆	◆	◆	◆	◆	◆
Hydraulic steady rest SLU-5(ø45-ø310)	◆	◆	◆	◆	◆	◆
Hydraulic steady rest SLU-5.1(ø80-ø350)	◆	◆	◆	◆	◆	◆
Air blow	◆	◆	◆	◆	◆	◆
Auto power off	◆	◆	◆	◆	◆	◆
Parts counter	◆	◆	◆	◆	◆	◆
Automatic front door	◆	◆	◆	◆	◆	◆
Tool setter	◆	◆	◆	◆	◆	◆
3" Boring bar tool holder	-	-	-	◆	-	◆
4" Boring bar tool holder	-	-	-	-	-	◆
High pressure coolant pump system	◆	◆	◆	◆	◆	◆

☆ STANDARD ACCESSORIES ◆ OPTIONAL ACCESSORIES - NO

**TAIWAN TAKISAWA TECHNOLOGY CO., LTD.**

[www.takisawa.com.tw](http://www.takisawa.com.tw)

No. 505, Sec-3, Yeng-Ping Road, Ping-Chen City, Taoyuan Hsien, Taiwan

TEL: +886-3-464-3166 FAX: +886-3-464-3674

E-mail: callcenter@takisawa.com.tw

DISTRIBUTOR

# TAKISAWA®

TAIWAN



## LS SERIES

LS-800 (M) (Y) / LS-1000 (M) / LS-1100  
EXTRA HEAVY DUTY  
CNC LATHE



# SUPER DUTY CNC TURNING CENTER

LS-800(M) / (1000) (1500) (2000) (3000)

LS-800(Y) / (2000) (3000)

LS-1000(M) / (1000) (1500) (2000) (3000)

LS-1100 / (3000)

## TAKISAWA ADVANCED ENGINEERING AND MACHINE DESIGN

- Extra heavy duty one-piece cast iron construction featuring a high damping coefficient with minimal thermal deformation.
- The 45 degree slant bed design ensures optimum cutting conditions.
- The slideways, hardened by high frequency induction, offer ideal hardness characteristics.
- Hand scraped Turcite B ensures static as well as dynamic accuracy between all contact surfaces.
- Our highly rigid spindle features deformation resistance, powerful turning capability and rugged durability.
- Taiwan Takisawa's in-house manufactured extra heavy duty turret, 31.5" in diameter and 7.8" thick, features rapid positioning and high accuracy curvic coupling using the largest available diameter of 18 inches.
- The two-step gearbox offers extraordinarily high torque during low speed machining for superior heavy duty cutting performance.



# SPINDLE CAPABILITY

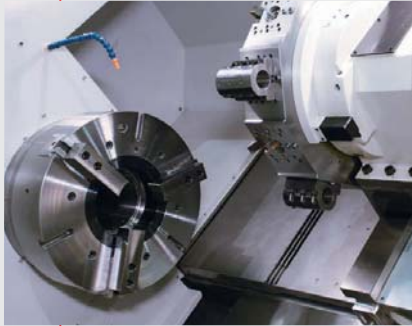

## LS-800

SPINDLE DRIVE MOTOR

<b>A / MY</b>	22/26 kW (30/35HP)
<b>B / MY</b>	22/26 kW (30/35HP) 30/37 kW (40/50HP)
<b>C / M</b>	30/37 kW (40/50HP) 37/45 kW (50/60HP)

MAX. SPINDLE SPEED (min<sup>-1</sup>)

2000 (15")
2000 (15") / 1500 (18")
2000 (15") / 1500 (18")
1200 (20")
1200 (20")

## LS-1000

SPINDLE DRIVE MOTOR

<b>A / MY</b>	30/37 kW (40/50 HP)
<b>B / M</b>	30/37 kW (40/50 HP) 37/45 kW (50/60 HP)

MAX. SPINDLE SPEED (min<sup>-1</sup>)

2000 (15")
1200 (20") / 1000 (24")
1200 (20") / 1000 (24")

## LS-1100

SPINDLE DRIVE MOTOR

<b>A / MY</b>	37/45 kW (50/60 HP)
<b>B / M</b>	45/55 kW (60/75 HP)

MAX. SPINDLE SPEED (min<sup>-1</sup>)

900
900

STANDARD  
OPTION

The Taiwan Takisawa spindle, manufactured in-house, incorporates high quality bearings sourced from Europe or Japan. The spindle is assembled into its finely bored cast iron housing in an air-conditioned clean room. Its design and precision manufacture ensure high accuracy coupled with easy maintenance and low cost for service and spare parts.



## GEAR BOX

All LS series CNC lathes have a gearbox made from 0-grade fine ground precision gears. The gearbox is designed for low temperature rise, low noise and low vibration and is assembled and test-run in a humidity and temperature controlled room to ensure these features. The Gearbox allows high cutting torque in its low speed range combined with a highly accurate surface finish.



# SPINDLE OUTPUT DIAGRAM

LS-1000(M) SPINDLE OUTPUT DIAGRAM

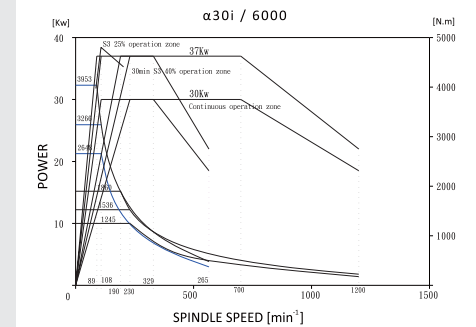

LS-800(M) B TYPE SPINDLE OUTPUT DIAGRAM

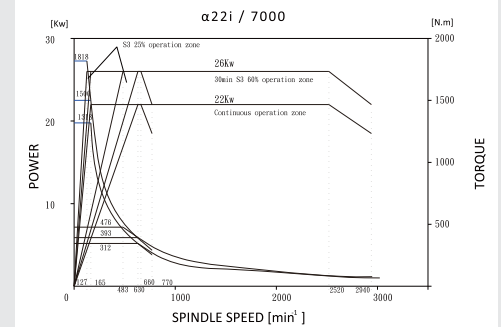

LS-1100 SPINDLE OUTPUT DIAGRAM

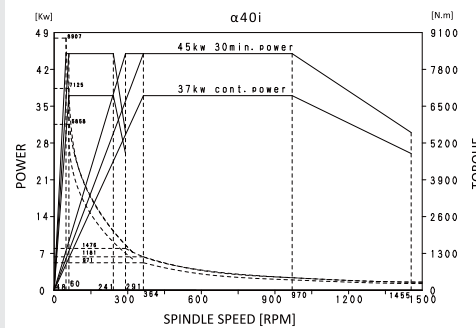

LS-1000(M) SPINDLE OUTPUT DIAGRAM

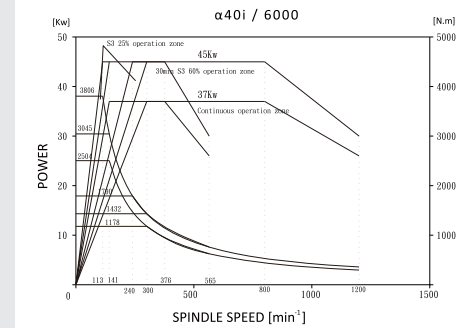

LS-800(M) B TYPE SPINDLE OUTPUT DIAGRAM

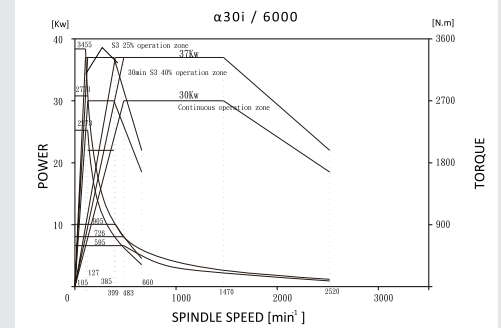

LS-1100 SPINDLE OUTPUT DIAGRAM

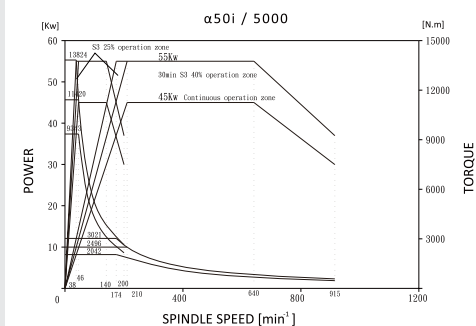

LS-800(M) A TYPE SPINDLE OUTPUT DIAGRAM

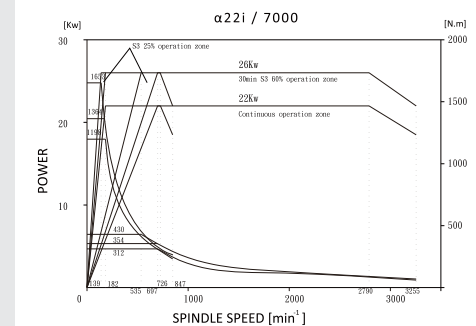

LS-800(M) C TYPE SPINDLE OUTPUT DIAGRAM

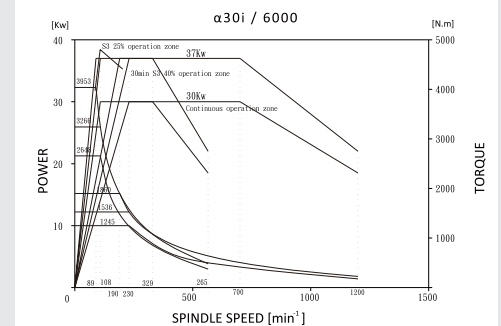

# TURRET CAPABILITY

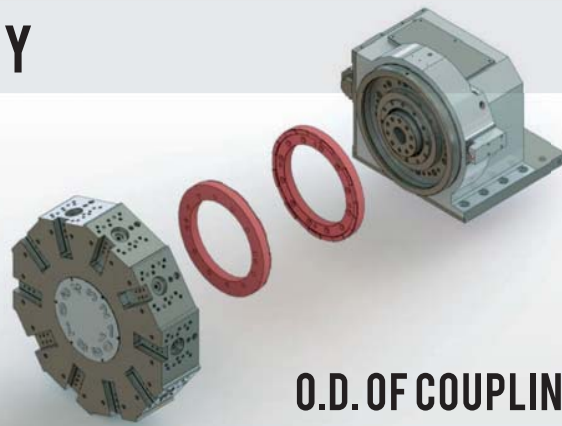

## O.D. OF COUPLING

The high performance turrets are all made by Taiwan Takisawa. The two-piece high precision coupling features high clamping force, rapid and accurate indexing and easy to calibrate positioning in both the CW and CCW direction.

LS-800: **250** mm

LS-1000: **360** mm

LS-1100: **460** mm



LS-800M/Y (std. 5.5/7.5kw, opt. 7.5/11kw)  
LS-1000M (std. 7.5/11kw)

## POWER CHART OF MILLING TOOL

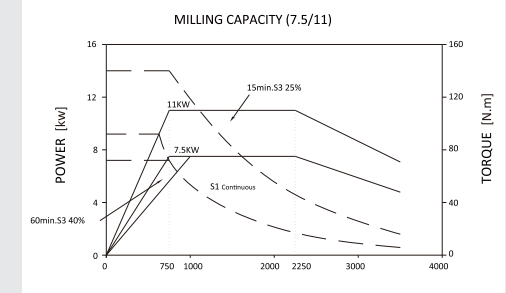
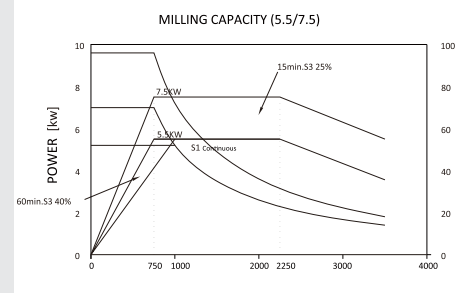

## MACHINING

O.D. HEAVY CUTTING		MACHINE MODEL	TOOL	SPINDLE SPEED	CUTTING FEEDRATE	CUTTING DEPTH	FEED PER REV.
	LS-800 ø1 22/7000	32 x 32 mm PCLNR 3232P 19	267 rpm	120 m/min	13 mm	0.8 mm/rev	
	LS-1100 ø1 50/5000	32 x 32 mm PCLNR 3232P 19	267 rpm	120 m/min	14 mm	0.8 mm/rev	
DRILL		MACHINE MODEL	TOOL	DRILLING DIA.	SPINDLE SPEED	CUTTING FEEDRATE	FEED PER REV.
	LS-800 ø1 22/7000	Drill	58 mm	250 rpm	120 m/min	0.3 mm/rev	
	LS-1100 ø1 50/5000	Drill	58 mm	250 rpm	120 m/min	0.3 mm/rev	



# FEEDING

Unit: m/min

	MACHINE MODEL	X AXIS FEEDRATE	Y AXIS FEEDRATE	Z AXIS FEEDRATE
 <p><b>BALL SCREW</b> Employs high precision high reliability ball screw offers faster rapid feedrate.</p>	<a href="#">LS-800 (M)</a>	16	---	L10 / L15 / L20 / L30 20 / 16 / 16 / 12
	<a href="#">LS-1000 (M)</a>	12	---	16 / 16 / 16 / 12
	<a href="#">LS-1100</a>	12	---	12
	<a href="#">LS-800Y</a>	12	6	L20 / L30 16 / 12

## LS Series STRUCTURE

All structural components of the machine are made of stress-relieved and deformation-free cast iron. Contact surfaces are hand scraped to ensure minimum tolerance accumulation.

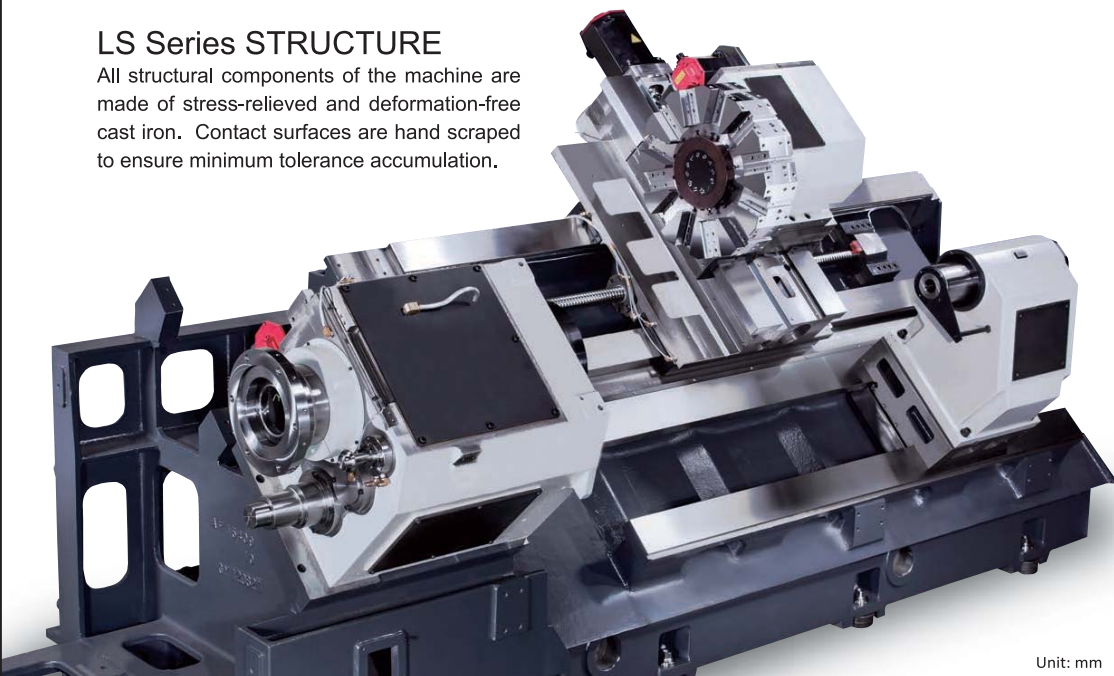

## TAIL STOCK CAPABILITY

Unit: mm

	MACHINE MODEL	QUILL DIAMETER	QUILL STROKE	CENTER TYPE
 <p>High thrust and strong clamping force ensures maximum stability especially when working with long workpieces.</p>	<a href="#">LS-800 (M) (Y)</a>	Fixed Quill: 125	120 / (150)	MT.5 (MT.6)
		Live Quill: 150		
	<a href="#">LS-1000 (M)</a>	Live Quill: 180	150	MT.6
	<a href="#">LS-1100</a>	Live Quill: 200	150	MT.6

# STANDARD ACCESSORIES



FANUC CONTROLLER



CHIP CONVEYOR



LUBRICATION PUMP

# OPTIONAL ACCESSORIES



INDEXING CHUCK



OIL COOLER



TOOL SENSOR

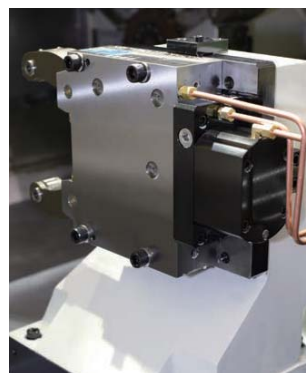

STEADY REST



OIL COOLER FOR GEARBOX



OIL MIST COLLECTOR



# TOOLING SYSTEM

## LS-800 INTERFERENCE DIAGRAM

<b>TOOL HOLDER</b>	<b>FACING HOLDER</b> AH22003-001(mm) AH22027-001(inch)		
<b>BORING BAR</b>	<b>BUSH</b> ø6(mm) AH22055-001 ø1/4"(inch) AH22079-001 ø8(mm) AH22056-001 ø5/16"(inch) AH22080-001 ø10(mm) AH22057-001 ø3/8"(inch) AH22081-001 ø12(mm) AH22058-001 ø1/2"(inch) AH22082-001 ø16(mm) AH22059-001 ø5/8"(inch) AH22083-001 ø20(mm) AH22060-001 ø3/4"(inch) AH22084-001 ø25(mm) AH22061-001 ø1"(inch) AH22085-001 ø32(mm) AH22062-001 ø1-1/4"(inch) AH22086-001 ø40(mm) AH22063-001 ø1-1/2"(inch) AH22087-001 ø40(mm) AH22064-001 AH22051-002(mm) AH22076-002(inch)		<b>BORING BAR, DRILL HOLDER</b> AH21001-001(mm) AH21002-001(inch)
<b>DRILL</b>	<b>BUSH</b> MT.1(mm) AH22090-001 MT.1(inch) AH22090-001 MT.2(mm) AH22096-001 MT.2(inch) AH22091-001 MT.3(mm) AH22067-001 MT.3(inch) AH22092-001 MT.4(mm) AH22068-001 MT.4(inch) AH22093-001		<b>BORING BAR, DRILL HOLDER(3")</b>
<b>U DRILL</b>	<b>BUSH</b> ø16(mm) AH22070-001 ø16"(inch) AH22095-001 ø20(mm) AH22071-001 ø20"(inch) AH22091-001 ø25(mm) AH22072-001 ø25"(inch) AH22092-001 ø32(mm) AH22073-001 ø32"(inch) AH22093-001 ø40(mm) AH22074-001 ø40"(inch) AH22093-001		<b>U DRILL HOLDER</b> AH22054-002(mm) AH22078-002(inch)

## LS-1000 INTERFERENCE DIAGRAM

<b>TOOL HOLDER</b>	<b>TURNING HOLDER</b> NJ22032-001(mm)		<b>LS-1000 TURRET 12T</b> NQ21102-001
<b>BORING BAR</b>	<b>FACING HOLDER</b> NJ22017-001(mm) NJ22003-001(inch)		
<b>BORING BAR</b>	<b>BUSH</b> ø20(mm) NJ22024-001 ø3/4"(inch) NJ22011-001 ø25(mm) NJ22025-001 ø1"(inch) NJ22012-001 =25L(mm) NJ22026-001 =25L(inch) NJ22013-001 =25L(mm) NJ22027-001 =25L(inch) NJ22014-001 ø32(mm) NJ22029-001 ø40(mm) NJ22030-001 ø50(mm) NJ22031-001		<b>BORING BAR, DRILL HOLDER</b> NJ22015-001(mm) NJ22001-001(inch)
<b>DRILL</b>	<b>BUSH</b> MT.4(mm) NJ22032-001 MT.4(inch) NJ22010-001 MT.5(mm) NJ22022-001 MT.5(inch) NJ22009-001		<b>LS-1100 TURRET 10T</b> NQ21502-001
<b>U DRILL</b>	<b>BUSH</b> ø32(mm) NJ22018-001 ø1-1/4"(inch) NJ22005-001 ø40(mm) NJ22019-001 ø1-1/2"(inch) NJ22006-001 ø45(mm) NJ22020-001 ø1-3/4"(inch) NJ22007-001 ø50(mm) NJ22021-001 ø2"(inch) NJ22008-001		<b>U DRILL HOLDER</b> NJ22016-001(mm) NJ22002-001(inch)

## LS-800(M / Y) INTERFERENCE DIAGRAM

<b>TOOL HOLDER</b>	<b>TURNING HOLDER</b> NQ22101-001(mm) NQ22105-001(mm)		
<b>BORING BAR</b>	<b>FACING HOLDER</b> NQ22102-001(mm) NQ22106-001(inch)		
<b>BORING BAR</b>	<b>BUSH</b> ø6(mm) NJ22005-001 ø1/4"(inch) NJ22030-001 ø8(mm) NJ22006-001 ø5/16"(inch) NJ22031-001 ø10(mm) NJ22007-001 ø3/8"(inch) NJ22032-001 ø12(mm) NJ22008-001 ø1/2"(inch) NJ22033-001 ø16(mm) NJ22009-001 ø5/8"(inch) NJ22034-001 ø20(mm) NC00004-095 ø3/4"(inch) NC00004-563 ø25(mm) NC00004-096 ø1"(inch) NC00004-564 ø32(mm) NC00004-097 ø1-1/4"(inch) NC00004-565 ø40(mm) NC00004-098 ø1-1/2"(inch) NC00004-566		<b>BORING BAR, DRILL HOLDER</b> NQ22103-001(mm) NQ22107-001(inch)
<b>DRILL</b>	<b>BUSH</b> MT.1(mm) NJ22014-001 MT.1(inch) NJ22039-001 MT.2(mm) NJ22015-001 MT.2(inch) NJ22040-001 MT.3(mm) NJ22016-001 MT.3(inch) NJ22041-001 MT.4(mm) NJ22017-001 MT.4(inch) NJ22042-001		<b>TURRET(12T)</b> NQ21101-001(mm) NQ21102-001(inch)
<b>U DRILL</b>	<b>BUSH</b> ø16 NJ22023-001 ø20 NJ22019-001 ø25 NJ22020-001 ø32 NJ22021-001 ø40 NJ22022-001		<b>U DRILL HOLDER</b> NJ22016-001(mm) NQ22018-001(inch)

## LS-1000M INTERFERENCE DIAGRAM

<b>TOOL HOLDER</b>	<b>TURNING HOLDER</b> NJ22126-001(mm) NJ22127-001(mm)		
<b>BORING BAR</b>	<b>FACING HOLDER</b> FA22124-001(mm) NJ22125-001(inch)		
<b>BORING BAR</b>	<b>BUSH</b> ø8(mm) NJ22104-001 ø5/16"(inch) NJ22128-001 ø10(mm) NJ22105-001 ø3/8"(inch) NJ22129-001 ø12(mm) NJ22106-001 ø1/2"(inch) NJ22130-001 ø16(mm) NJ22107-001 ø5/8"(inch) NJ22131-001 ø20(mm) NJ22108-001 ø3/4"(inch) NJ22132-001 ø25(mm) NJ22109-001 ø1"(inch) NJ22133-001 ø32(mm) NJ22110-001 ø1-1/4"(inch) NJ22134-001 ø40(mm) NJ22111-001 ø1-1/2"(inch) NJ22135-001 ø50(mm) NJ22112-001 ø2"(inch) NJ22136-001		<b>BORING BAR, DRILL HOLDER</b> NJ22122-001(mm) NJ22123-001(inch)
<b>DRILL</b>	<b>BUSH</b> MT.1(mm) NJ22113-001 MT.1(inch) NJ22137-001 MT.2(mm) NJ22114-001 MT.2(inch) NJ22138-001 MT.3(mm) NJ22115-001 MT.3(inch) NJ22139-001 MT.4(mm) NJ22116-001 MT.4(inch) NJ22140-001 MT.5(mm) NJ22117-001 MT.5(inch) NJ22141-001		<b>TURRET(12T)</b> NQ21102-001
<b>U DRILL</b>	<b>BUSH</b> ø20(mm) NJ22019-001 ø20L(inch) NJ22020-001 ø25(mm) NJ22021-001 ø25L(inch) NJ22022-001 ø32(mm) NJ22023-001 ø32L(inch) NJ22024-001 ø40(mm) NJ22025-001 ø40L(inch) NJ22026-001		

# MACHINE DIMENSIONS

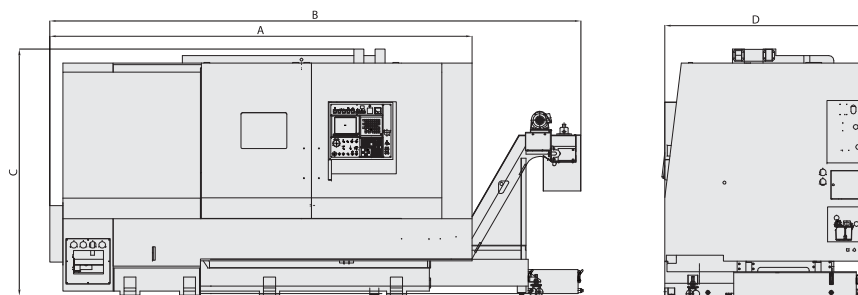

	LS-800L10	LS-800L15	LS-800L20	LS-800L30	LS-800ML10	LS-800ML15	LS-800ML20	LS-800ML30	LS-800YL30	LS-800YL30
A	4537	4967	5467	6467	4537	4967	5467	6467	6985	6985
B	5623	6053	6553	7553	5623	6053	6553	7553	7071	8071
C	2423	2423	2423	2423	2423	2423	2423	2423	2760	2760
D	2143	2143	2143	2143	2143	2143	2143	2143	2194	2194

\* Specifications are subject to change without notice.

# MACHINE DIMENSIONS

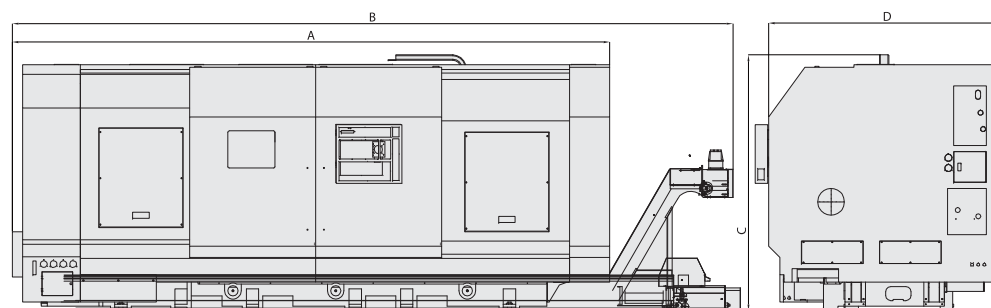

	LS-1000L10	LS-1000L15	LS-1000L20	LS-1000L30	LS-1000ML10	LS-1000ML15	LS-1000ML20	LS-1000ML30	LS-1100
A	4810	5310	5810	7062	4810	5310	5810	7062	7062
B	6010	6510	7010	8262	6010	6510	7010	8262	8262
C	2490	2490	2490	2490	2490	2490	2490	2490	2490
D	2300	2300	2300	2300	2300	2300	2300	2300	2300

\* Specifications are subject to change without notice.

# LS SERIES SPECIFICATIONS

TAIWAN TAKISAWA TECHNOLOGY CO., LTD.

		LS-800 series			LS-800M series			LS-800Y	LS-1000 series	LS-1000M series	LS-1100
MODEL		A	B	C	MA	MB	MC				
ITEM	Unit	L10/L15/L20/L30	L10/L15/L20/L30	L10/L15/L20/L30	L10/L15/L20/L30	L10/L15/L20/L30	L10/L15/L20/L30	L20/L30	L10/L15/L20/L30	L10/L15/L20/L30	L30
<b>CAPACITY</b>											
Max. swing	mm	830			830			830	1020	1020	1120
Swing over saddle	mm	660			660			660	780	780	910
SD. Turning diameter	mm	266(330)			300			300	320	330	440
Max. Turning diameter	mm	760			680			600	900	850	900
Max. Turning length	mm	1100/1600/2100/3100	1095/1595/2095/3095	1050/1550/1950/2950	988/1488/1988/2988	985/1485/1985/2985	937/1437/1937/2937	1914/2914	1031/1531/2131/3131	970/1470/1970/2970	3000
Bar work capacity	mm	90	105	180	90	105	180	105	180	180	254
<b>TRAVEL</b>											
X Axis travel	mm	390			390			390	500	500	540
Z Axis travel	mm	1150/1650/2150/3150			1150/1650/2150/3150			2048/3048	1100/1600/2100/3100	1100/1600/2100/3100	3100
Y Axis travel	mm	---	---	---	---	---	---	±80	---	---	---
<b>SPINDLE</b>											
Spindle speed	rpm	2000	2000(1500)	1200	2000	2000(1500)	1200	2000(1500)	1200(1000)	1200(1000)	905
Chuck size		15"	15"(18")	20"	15"	15"(18")	20"	15"(18")	20"(24")	20"(24")	32"
Spindle nose		A2-8	A2-11	A2-15	A2-8	A2-11	A2-15	A2-11	A2-15	A2-15	A2-20
Through hole diameter	mm	102	117	200	102	117	200	117	200	200	275
Bearing diameter	mm	140	160	266	140	160	266	160	266	266	360
<b>TURRET</b>											
Number of tool stations		T10(T12)			T12			T12	T10	T12	T10
Shank height for square tool	mm	32			32			32	32	32	32
Shank diameter for boring bar	mm	50(60)			50			50	65(75)	63	65/(75)/(100)
Milling tool shank diameter	mm	---	---	---	---	26	---	26	---	34	---
<b>TAILSTOCK</b>											
Tailstock travel	mm	1000/1500/2000/3000			1000/1500/2000/3000			2000/3000	1000/1500/2000/3000	1000/1500/2000/3000	3000
Tailstock spindle diameter	mm	125(150)			125(150)			125	180	180	200
Taper hole of tailstock spindle		MT.5(MT.6)			MT.5(MT.6)			MT.5(MT.6)	MT.6	MT.6	MT.6
Tailstock spindle travel	mm	120			120			120	150	150	150
<b>FEEDRATE</b>											
X axis rapid traverse rate	m/min	12			12			12	12	12	12
Z axis rapid traverse rate	m/min	20/16/16/12			20/16/16/12			16/12	16/16/16/12	16/16/16/12	12
Y axis rapid traverse rate	m/min	---	---	---	---	---	---	6	---	---	---
<b>MOTOR</b>											
Spindle drive motor	KW	22/26	22/26(30/37)	30/37	22/26	22/26(30/37)	30/37	22/26(30/37)	30/37(37/45)	30/37(37/45)	37/45(45/55)
Turret index motor	KW	1.2			1.2			1.2	1.2	1.2	---
Milling motor	KW	---			5.5/7.5(7.5/11)			5.5/7.5(7.5/11)	---	7.5/11	---
X axis drive motor	KW	4			4			7	4	4	6
Z axis drive motor	KW	4(7)/4(7)/7/7	4(7)/4(7)/7/7	7/7/7/7	4(7)/4(7)/7/7	4(7)/4(7)/7/7	7/7/7/7	7/7	6	6	6(11)
Y axis drive motor	KW	---			---			7	---	---	---
<b>MACHINE SIZE</b>											
Height	mm	2300			2300			2800	2590	2590	2728
Width	mm	4300/4700/5300/6400			4300/4700/5300/6400			5300/6400	5062/5562/6062/7062	5062/5562/6062/7062	7530
Depth	mm	2180			2180			2180	2180	2180	2600
Weight	kg	10200/11000/13300/14800	10500/11300/13600/15100	11500/12300/14600/16100	10300/11100/13500/15000	10600/11400/13700/15200	11600/12400/14700/16200	15500/17000	12000/13500/16500/18000	12000/13500/16500/18000	27000

\* Specifications are subject to change without notice. \* ( ) option